

R9 Modul II

Montageanleitung

Assembly instructions

Notice de montage

Istruzioni per il montaggio

Instrucciones de montaje

Инструкция по монтажу

组装说明

Module II

Module II

Modulo II

Módulo II

Модуль II

模块二

02.2023

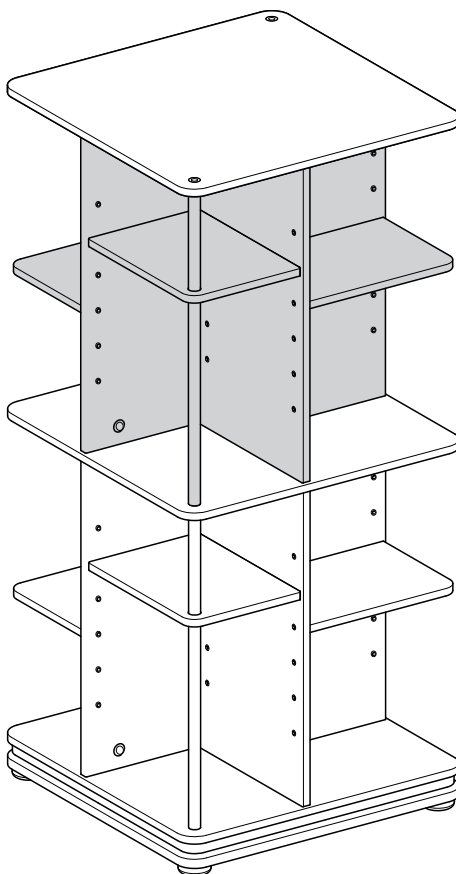

D

Allgemeine Hinweise

Möbel sollten generell in klimatisierten Lagerräumen gelagert werden, da sie sonst unter Hitze, Kälte oder hoher Luftfeuchtigkeit leiden können. Durch Temperaturschwankungen können sich Möbel verziehen und dadurch Schaden nehmen.

Wir empfehlen eine Lagerung bei einer konstanten Luftfeuchtigkeit von 50 bis 60 %. Bei abgeschalteten Klimaanlage kann bei hoher Luftfeuchtigkeit Kondenswasser entstehen, das auf Holzteilen Flecken verursachen und lackierte Oberflächen beschädigen kann.

GB

General information

Furniture should generally be stored in a climate-controlled environment, otherwise it may suffer from heat, cold or high humidity. Temperature fluctuations can cause furniture to deform and thus be damaged.

We recommend storage at a constant humidity of 50 to 60%.

When air conditioning is switched off, high humidity can cause condensation, which can stain wooden parts and damage painted surfaces.

F

Information générales

Les meubles doivent généralement être stockés dans des locaux climatisés, sous peine de souffrir de la chaleur, du froid ou d'une forte humidité. Les fluctuations de température peuvent entraîner la déformation des meubles et donc les endommager.

Nous recommandons un stockage à un taux d'humidité constant de 50 à 60 %. Lorsque la climatisation est éteinte, une humidité élevée peut provoquer de la condensation, qui peut tacher les parties en bois et endommager les surfaces peintes.

I

Note generali

In genere i mobili devono essere conservati in magazzini climatizzati, altrimenti potrebbero soffrire il caldo, il freddo o l'umidità elevata. Gli sbalzi di temperatura possono causare la deformazione dei mobili e quindi il loro danneggiamento.

Si consiglia di conservare i mobili a un'umidità costante compresa tra il 50 e il 60%. Quando l'aria condizionata è spenta, l'elevata umidità può causare condensa, che può macchiare le parti in legno e danneggiare le superfici verniciate.

E

Notas generales

Por lo general, los muebles deben guardarse en almacenes con climatización controlada, ya que de lo contrario pueden sufrir el calor, el frío o la alta humedad. Las fluctuaciones de temperatura pueden hacer que los muebles se deformen y se dañen.

Se recomienda almacenar a una humedad constante del 50 al 60%.

Cuando el aire acondicionado está apagado, la alta humedad puede causar condensación, que puede manchar las piezas de madera y dañar las superficies pintadas.

RUS

Общие сведения

Мебель, как правило, следует устанавливать/хранить в кондиционируемых помещениях, иначе она может пострадать от жары, холода или повышенной влажности. Перепады температуры могут привести к деформации мебели и, как следствие, ее повреждению.

Мы рекомендуем хранение при постоянной влажности воздуха от 50 до 60%. Если кондиционеры выключены, то при высокой влажности воздуха может возникнуть конденсат, от которого могут появиться пятна на деревянных поверхностях и повреждения на лакированных частях.

CHN

通用信息

家具通常应存放空调房中，否则会因过热、过冷或受潮而损坏。温度波动会使家具变形并造成损坏。我们建议在50–60%的恒定湿度下储存。当空调关闭时，在高湿度下会形成冷凝，这可能会污染木制部件并损坏涂漆面板。

D

Sicherheitshinweise

- ⚠ Die Montage darf nur durch geeignete Personen erfolgen.
- ⚠ Das Möbel darf nur für seinen bestimmungsgemäßen Gebrauch verwendet werden.
- ⚠ Kleinteile von Kleinkindern fernhalten.

GB

Safety instructions

- ⚠ Assembly may only be carried out by qualified persons.
- ⚠ The furniture is only to be used for its intended purpose.
- ⚠ Keep small items out of the reach of small children.

F

Consignes de sécurité

- ⚠ Le montage doit être confié uniquement à des personnes compétentes.
- ⚠ Ce meuble doit servir exclusivement à l'usage qui en est fait habituellement.
- ⚠ Conserver les petites pièces hors de portée des enfants en bas âge.

I

Istruzioni di sicurezza

- ⚠ Fare eseguire il montaggio esclusivamente da persone idonee.
- ⚠ Utilizzare questo mobile esclusivamente per l'uso previsto.
- ⚠ Tenere i pezzi piccoli lontano dalla portata dei bambini.

E

Instrucciones de seguridad

- ⚠ El montaje sólo podrá ser ejecutado por personas aptas para el mismo.
- ⚠ El mueble sólo podrá ser utilizado para un uso conforme al prescrito.
- ⚠ Mantengalas piezas pequeñas fuera del alcance de los niños pequeños.

RUS

Указания по безопасности

- ⚠ Монтаж должен выполняться только лицами, имеющими необходимые навыки.
- ⚠ Мебель должна использоваться только по ее прямому назначению.
- ⚠ Мелкие детали могут быть опасны для детей - храните их в недоступности от ребенка!

CHN

安全提示

- ⚠ 组装需要由专业人员完成。
- ⚠ 家具的使用要合理，要符合其用途。
- ⚠ 不要让小孩子接触小件(如装饰和色彩元素)

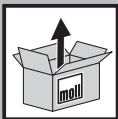

Alles auspacken und Inhalt auf Vollständigkeit prüfen
Unpack the contents and check for completeness
Déballez tout et vérifiez que le contenu est bien complet
Togliere la forniture dall'imballo e accertarsi che non ci siano pezzi mancanti
Desempaque todos los elementos y compruebe que no falta ninguno
Распакуйте содержимое и проверьте его на комплектность
拆开所有包装并检查是否齐全

R9 Modul II
Module II
Modulo II
Módulo II
Модуль II
模块二

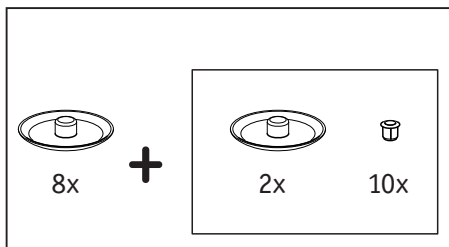
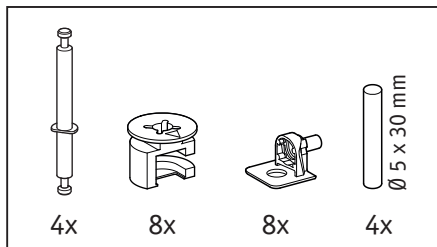
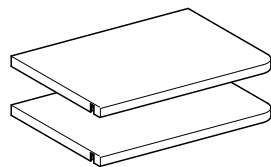
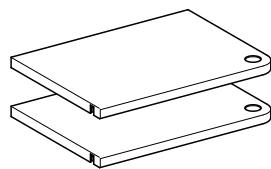
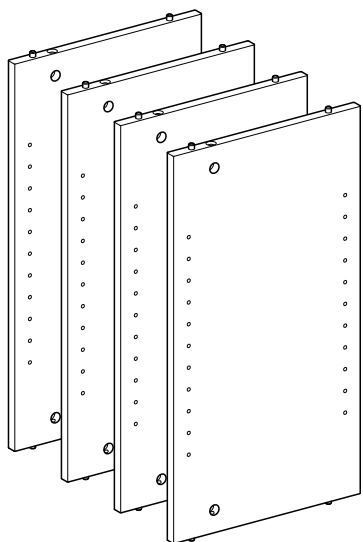
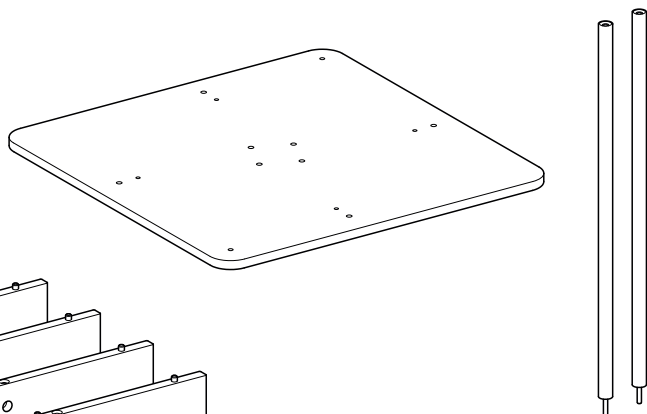

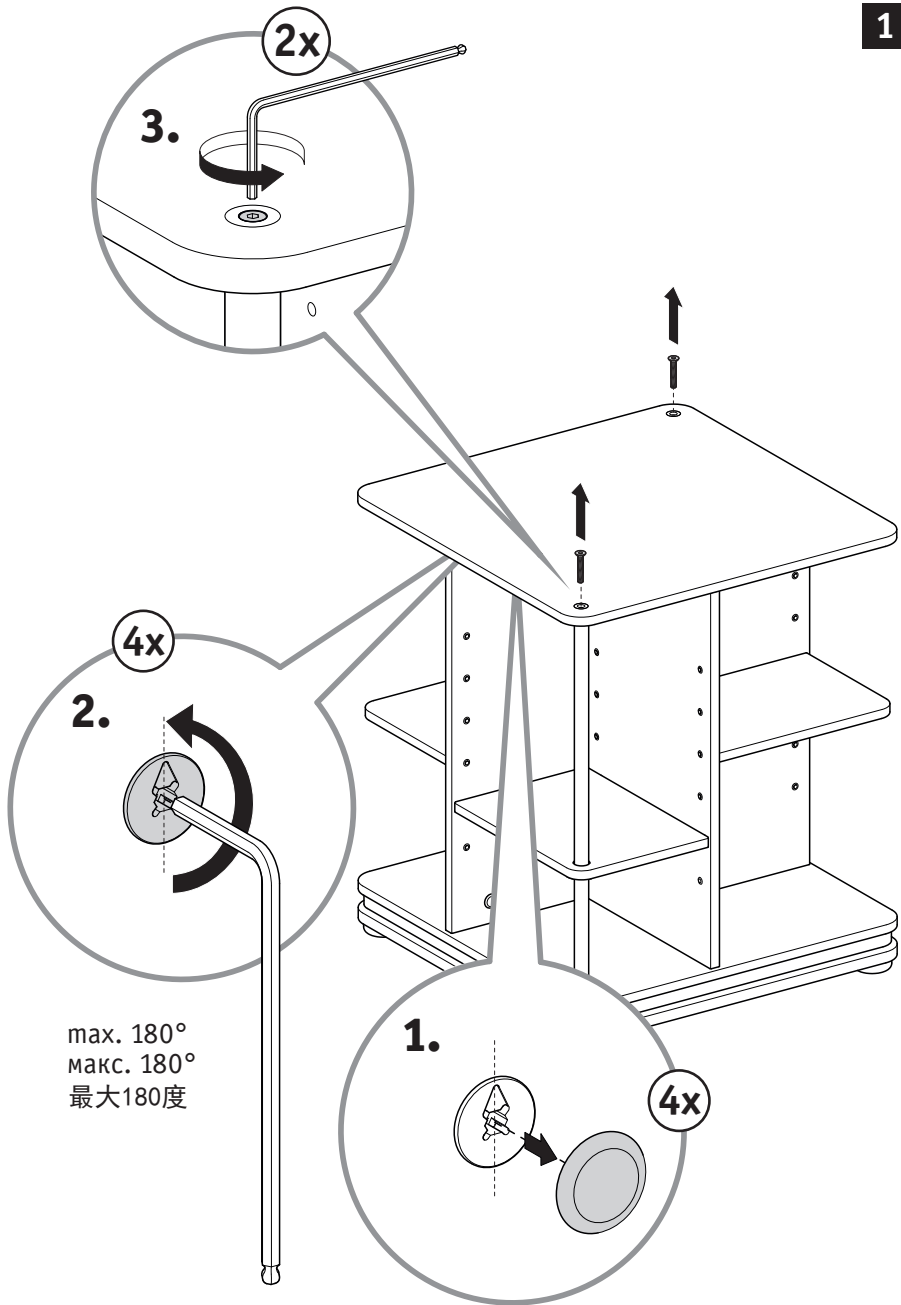

2

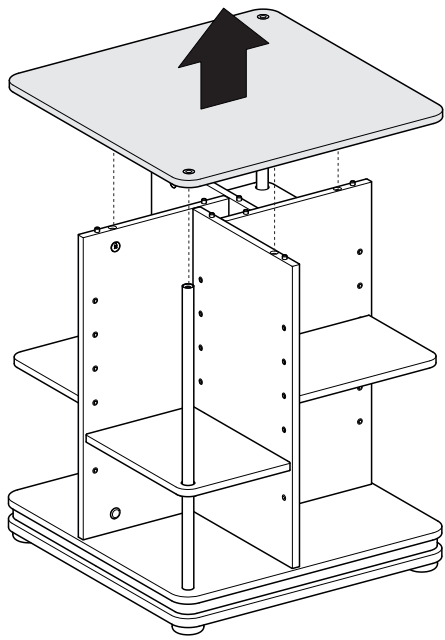

3

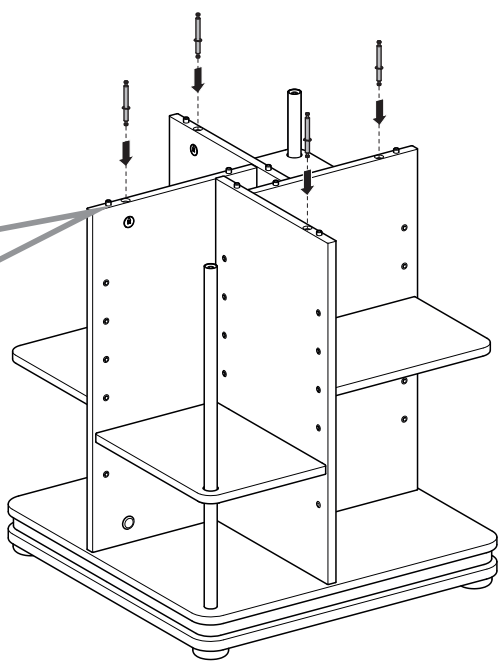
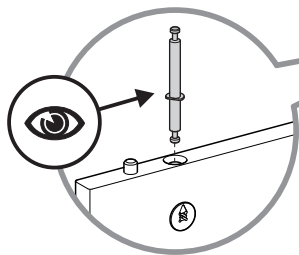
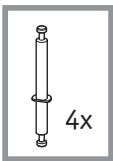

4

4x

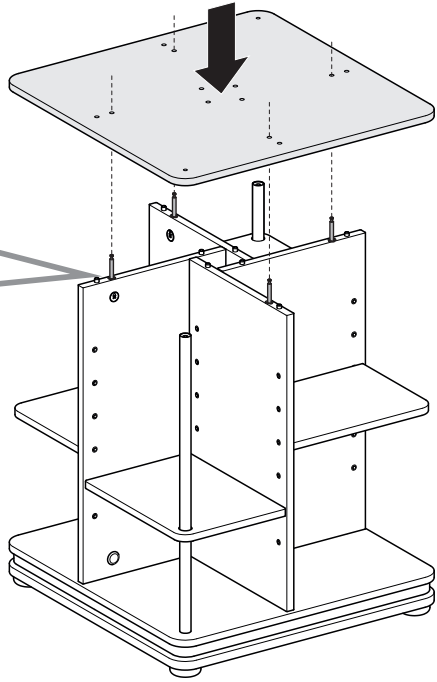

5

4x

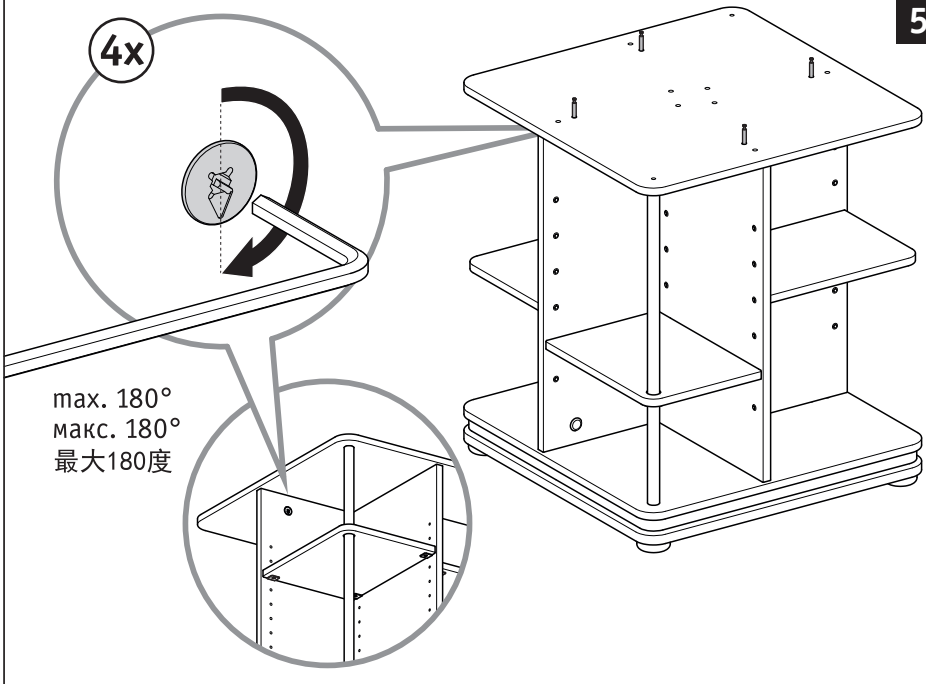

max. 180°
макс. 180°
最大180度

6

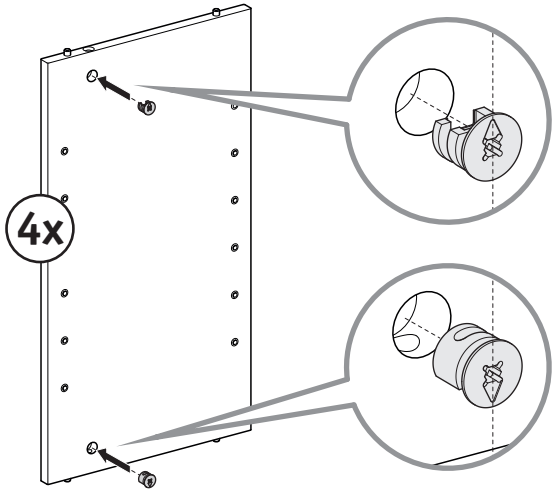
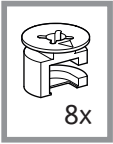

7

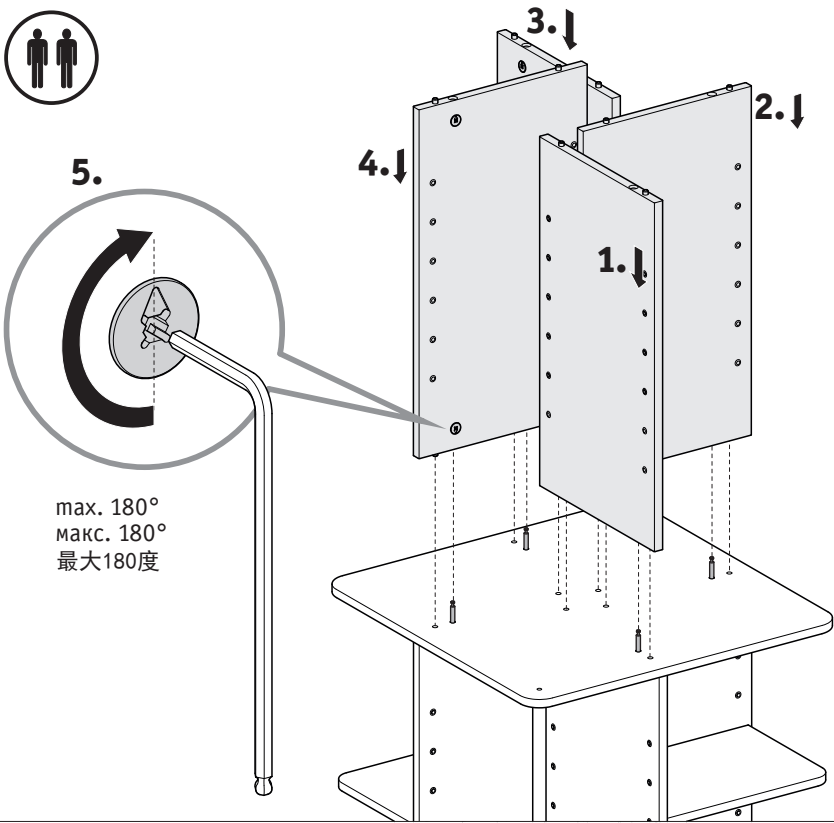

8

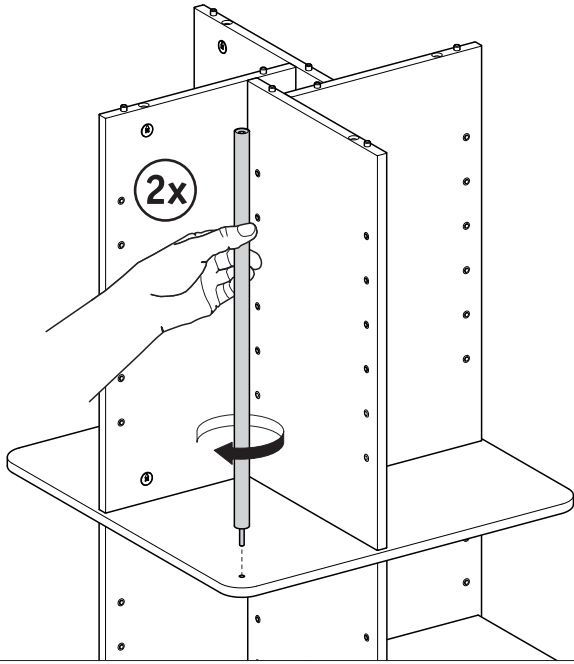
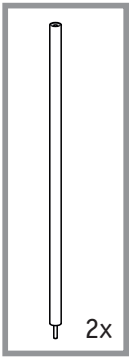

9

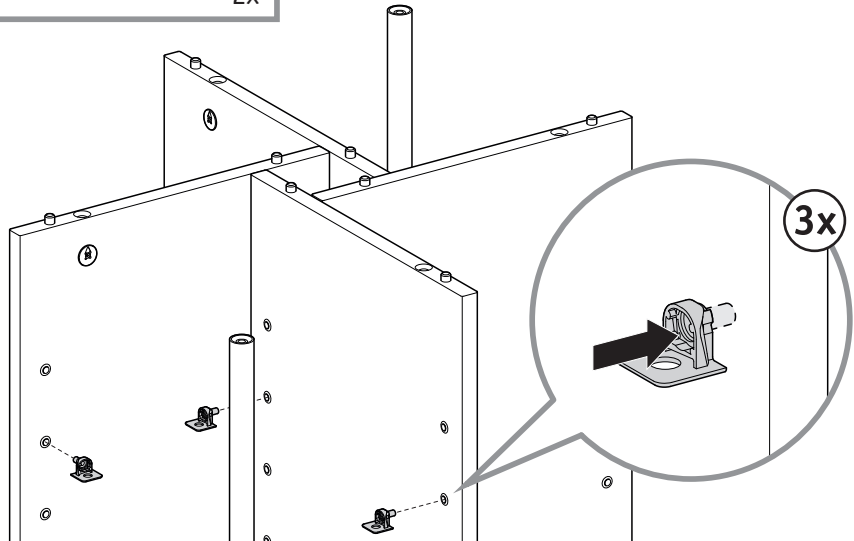
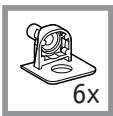
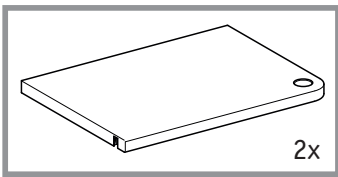

10

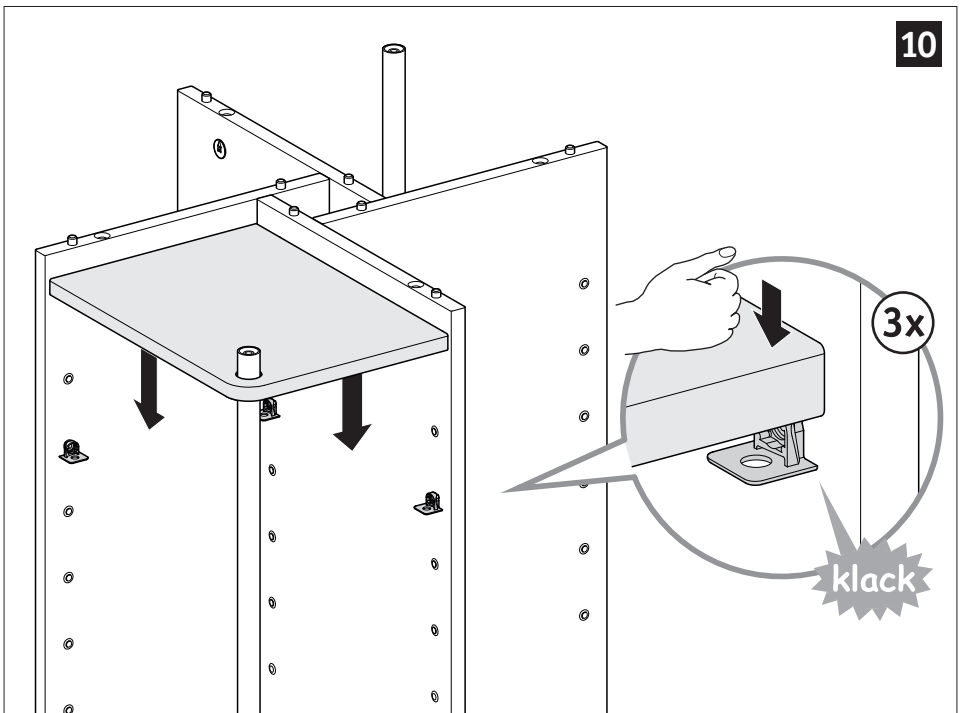

11

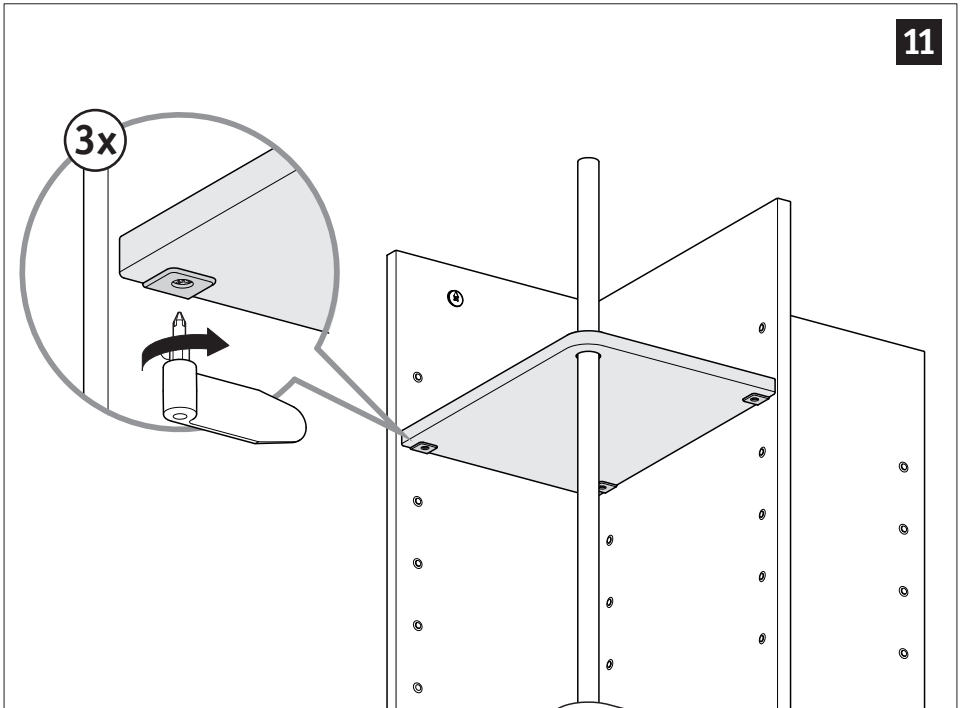

12

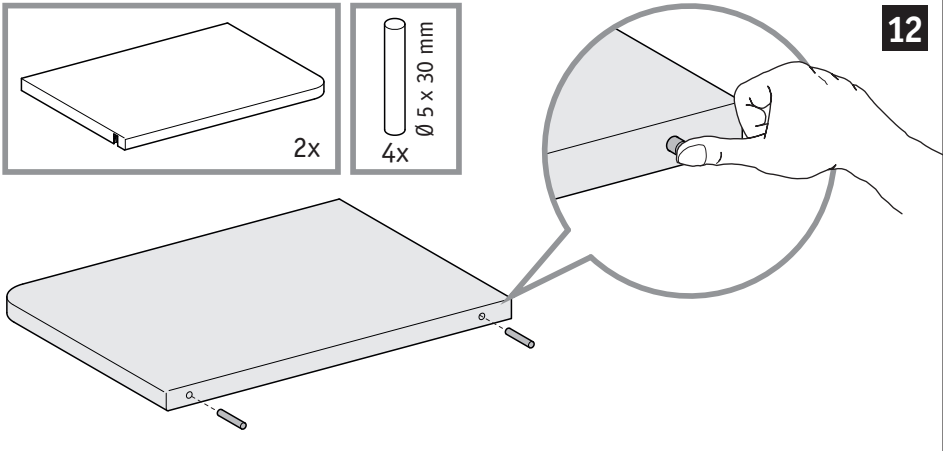

13

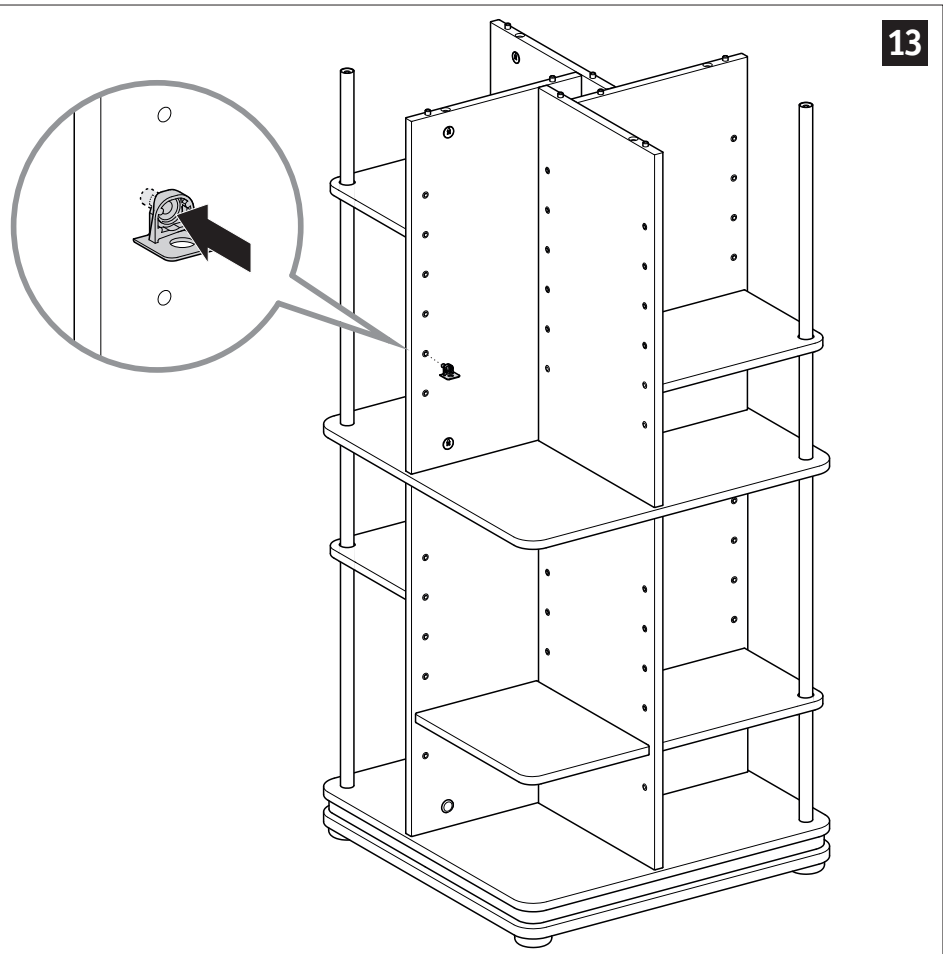

14

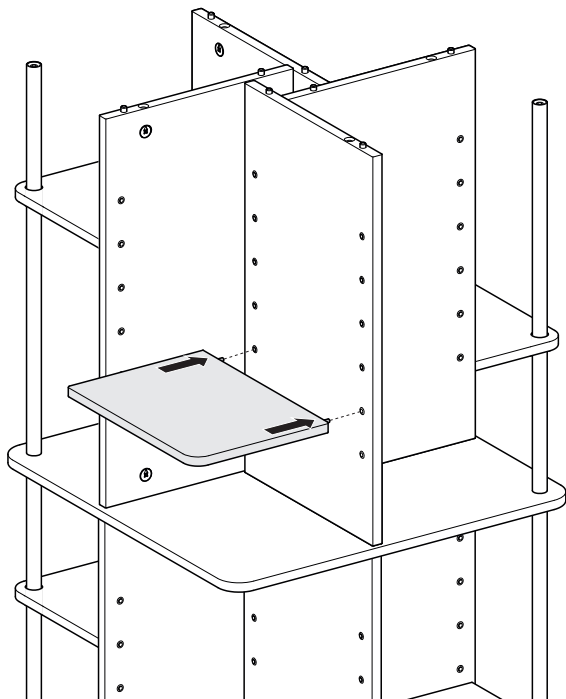

15

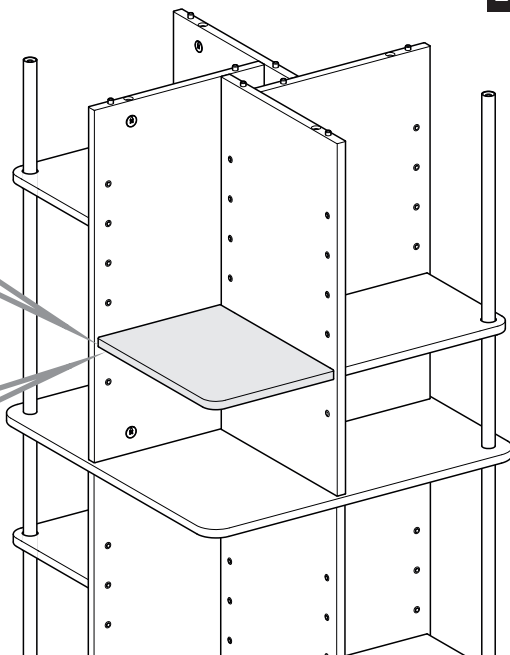
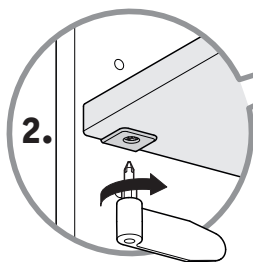
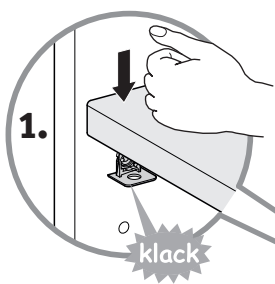

R9 Fachbodenset → Ja
R9 Shelf set → Yes
R9 Jeu de tablettes → Oui
R9 Set di scaffali → Si
R9 Juego de estanterías → Si
R9 Комплект полок → Да
搁置架 R9 → 是

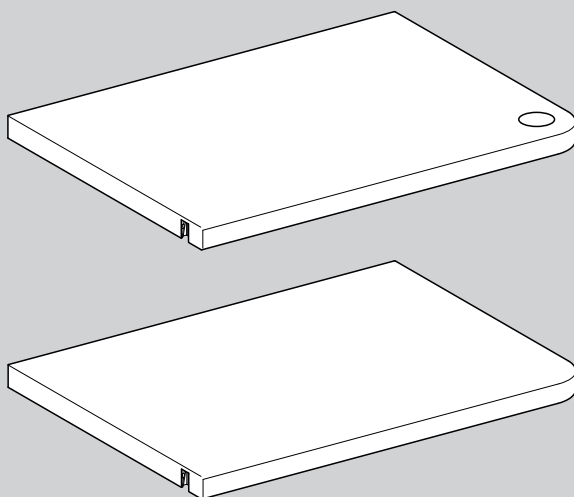
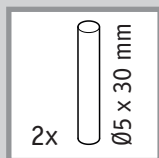
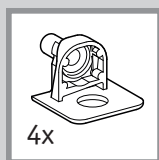
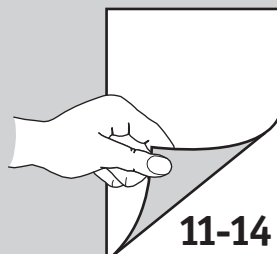

R9 Fachbodenset → Nein
R9 Shelf set → No
R9 Jeu de tablettes → Non
R9 Set di scaffali → No
R9 Juego de estanterías → No
R9 Комплект полок → Нет
搁置架 R9 → 没有

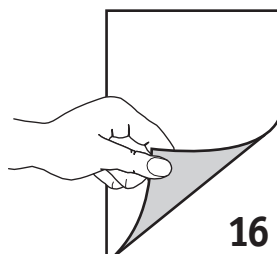

16

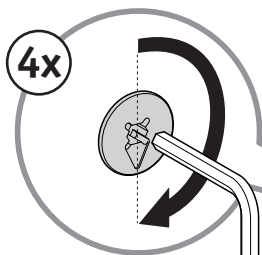

max. 180°
макс. 180°
最大180度

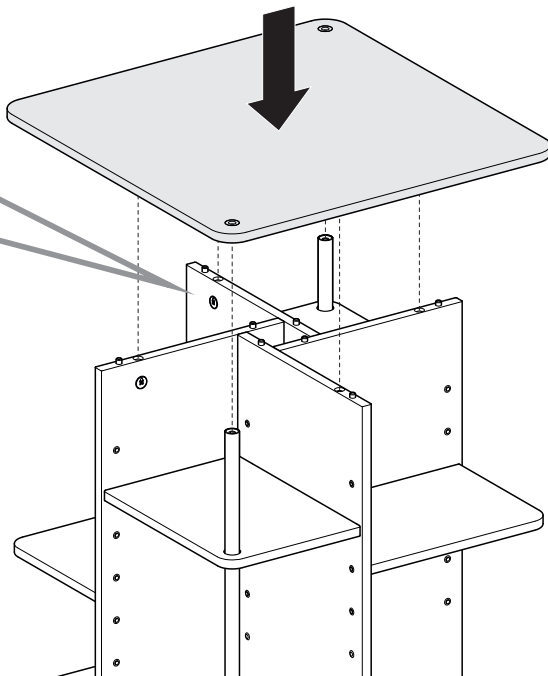

17

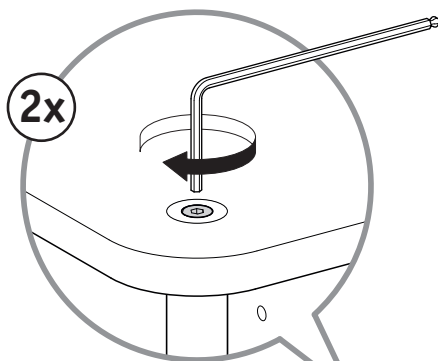
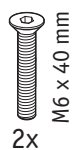

(D) Die Schrauben nur handfest (leicht) anziehen

(GB) Tighten the screws only hand-tight

(F) Serrez les vis uniquement à la main

(I) Serrare le viti solo a mano

(E) Apriete los tornillos sólo a mano

(RUS) Затяните винты вручную (легко)

(CHN) 只能用手拧紧螺丝

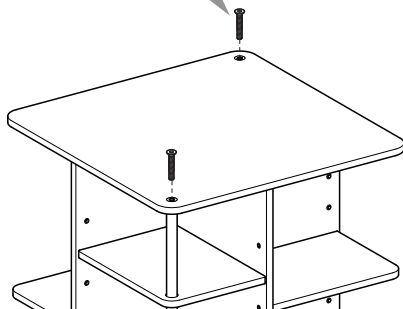

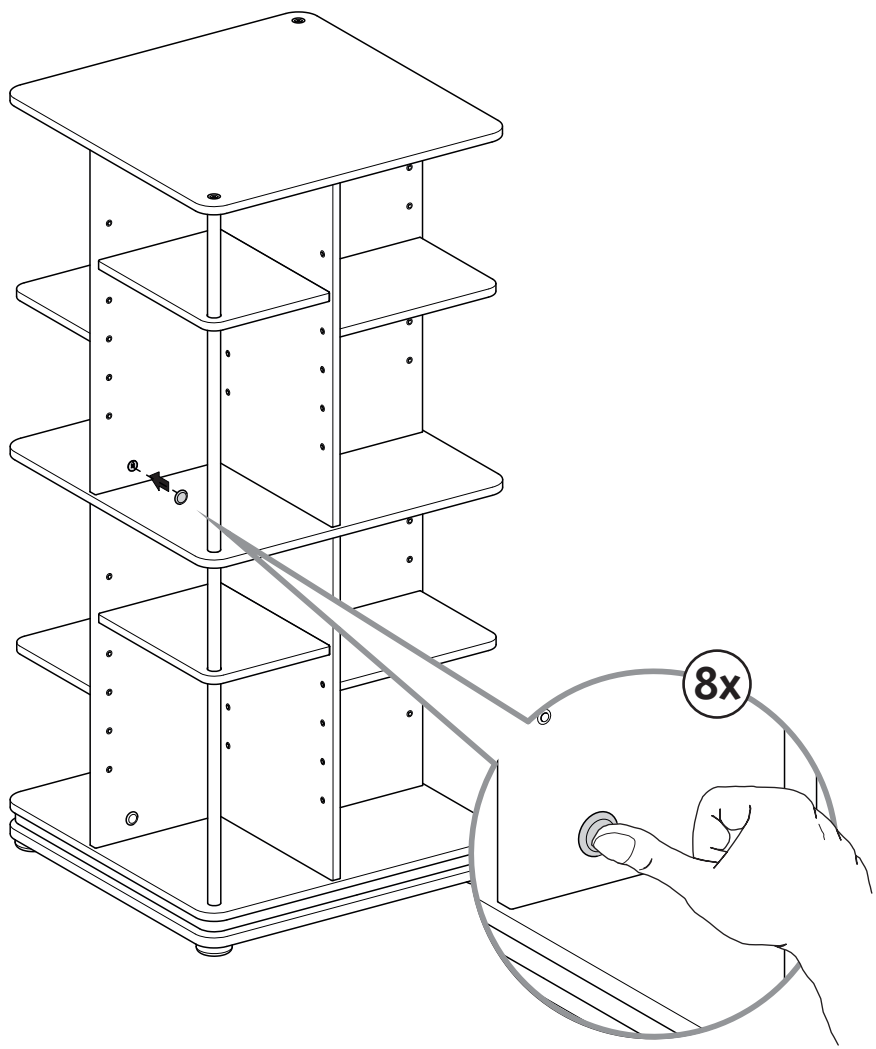

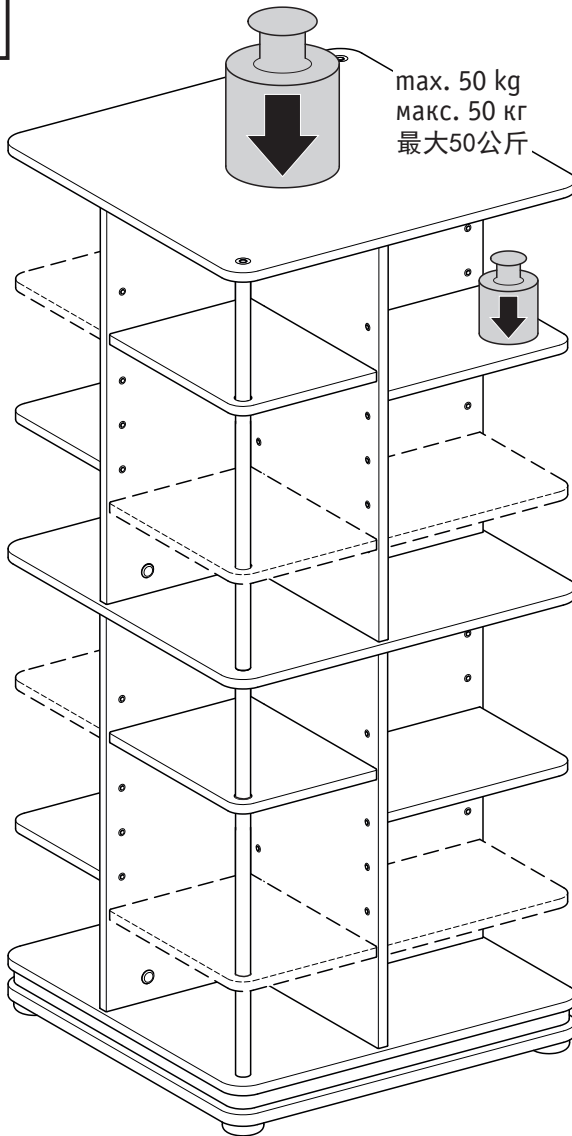

max. 50 kg
макс. 50 кг
最大50公斤

max. 2 kg
макс. 2 кг
最大2公斤

max. 16 Fachböden
max. 16 shelves
max. 16 étagères
max. 16 scaffali
max. 16 estanterías
макс. 16 Полки
最大16货架



maximale Höhe = 125 cm
maximum height = 125 cm
hauteur maximale = 125 cm
altezza massima = 125 cm
altura máxima = 125 cm
максимальная высота = 125 см
最高 = 125厘米



Ersatzteilübersicht
 List of spare parts
 Vue d'ensemble des pièces de rechange
 Elenco di ricambi

Lista de repuestos
 Запасные части
 备件清单

R9 Modul II

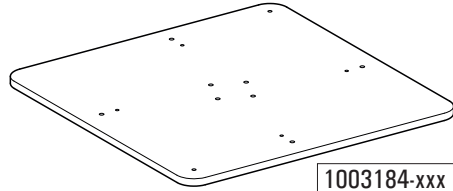

1003184-xxx

-206

weiss
 weiß
 blanc
 bianco
 blanco
 белый
 白色

-906

schwarz
 black
 noir
 nero
 negro
 черный
 黑色

-709

grau
 grey
 gris
 grigio
 gris
 серый
 灰色

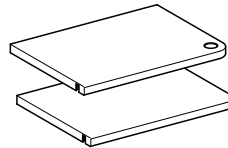

1003189-xxx

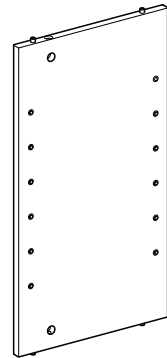

1003187-xxx

1001796-xxx

-710

silberfarben
 silver colored
 couleur argent
 color argento
 color plata
 Цвет серебристый
 银色

-900

schwarz
 black
 noir
 nero
 negro
 черный
 黑色

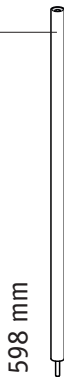

598 mm

1001808

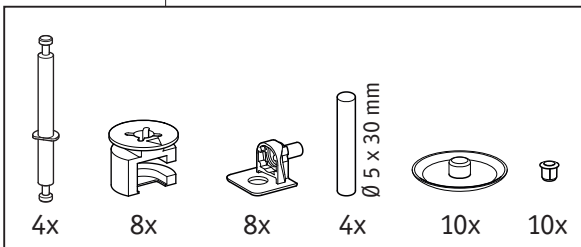

100181-xxx

-704

grau / grey / gris / grigio
 gris / серый / 灰色

-903

schwarz / black / noir / nero
 negro / черный / 黑色



10 x



10x

D Bitte bewahren Sie diese Montageanleitung auf!

GB Please carefully keep these assembly instructions

F Merci de conserver cette notice de montage!

I Si prega di conservare sempre le presenti istruzioni per il montaggio!

E Por favor, guarde estas instrucciones de montaje.

RUS Пожалуйста, храните данную инструкцию по монтажу

CHN 请妥善保存本组装说明！ 服务地址

